



**2.0T**  
Rated Load Capacity



**1.6m/s**  
Max. Safety Driving Speed



**125mm**  
Fork Lifting Height



**2600mm**  
Min. Stacking Aisle Width

# VNT20(VL)-01

## PALLET JACK AGV

By using 3D SLAM navigation and 3D Laser perception module on pallet jack AGV, the project implementation period is shortened and the AGV has high reliability; The AGV has light body weight with customizable forks and supporting legs based on different scenarios, which provides great flexibility, and strong adaptability; The pallet jack AGV is capable of working between different building floors.



# VNT20(VL)-01

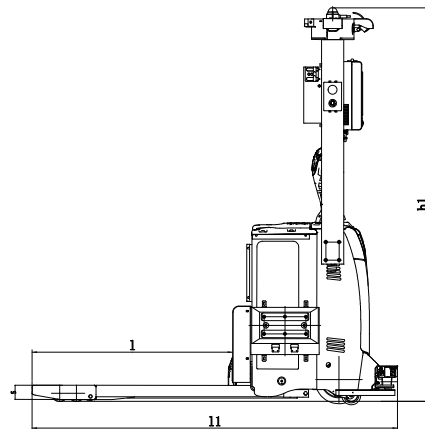
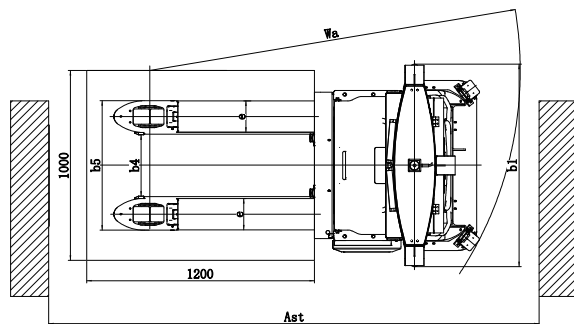

## TECHNICAL SPECIFICATIONS

Body Weight	750kg (1653.47lb)
Vehicle Dimensions (l1/b1/h1)	1925x900x2075mm (75.79x35.43x81.69in)
ForkDimensions (l/e/s)	1050x165x55mm (41.34x6.50x2.17in)
Optional Fork Dimensions Series	1150/1250/1350/1500/1600/1800mm (45.28x49.21x53.15x59.06x62.99x70.87in)
Fork Outer Width	560/680mm (22.05/26.77in)
Fork Inner Width	210/330mm (8.27/12.99in)
Positioning Method	3D SLAM navigation
Perception Method	3D Laser scanner
Goods Pick-up Self-adaptability	±100mm/±10° (±3.94in/±10°)

Fork Lifting Height	125mm (4.92in)
Rated Load Capacity	2000kg (4409.25lb)
Load Center Distance	600mm (23.62in)
Min. Turning Radius	1950mm (76.77in)
Stacking Accuracy	±10mm/±0.5° (±0.39in/±0.5°)
Operation Mode	Automatic / Stand up Manual
Battery Type	Lithium iron phosphate battery
Voltage/Battery Capacity	24V/270Ah
Charging Mode	Manual/ Automatic Charging

## MOTION PERFORMANCE

Straight Forward Speed (Full-Load/Empty-Load)	1.6m/s, 1.6m/s (3.58mph, 3.58mph)
Straight Backward Speed (Full-Load/Empty-Load)	0.6m/s, 0.6m/s (1.34mph, 1.34mph)
Forward Turning Speed (Full-Load/Empty-Load)	0.3m/s, 0.6m/s (0.67mph, 1.34mph)

Backward Turning Speed (Full-Load/Empty-Load)	0.3m/s, 0.6m/s (0.67mph, 1.34mph)
Lifting Up Speed (Full-Load/Empty-Load)	36mm/s, 43mm/s (0.08mph, 0.10mph)
Lifting Down Speed (Full-Load/Empty-Load)	64mm/s, 60mm/s (0.14mph, 0.13mph)

## ENVIRONMENTAL REQUIREMENT

Min. Stacking Aisle Width (Pallet Size L*W:1200*1000mm, Across Forks On Width)	2600mm (102.36in)
Min. Turning Aisle Width (Pallet Size L*W:1200*1000mm, Across Forks On Width)	2150mm (84.65in)
Working Temperature	-5°C~40°C
Working Humidity	20%~95%

Ground Flatness	±5mm/m <sup>2</sup> (±0.20in/m <sup>2</sup> )
Max. Climbing Capability (Full-Load/Empty-Load)	5%, 5% (3°, 3°)
Max. Groove Width	30mm (1.18in)
Maxi. Step Height	10mm (0.39in)

## SAFETY PROTECTION

Front	Laser Scanner Protection + Anti-Collision Bumper
Rear	Laser Scanner Protection + Non-Contact Sensor
Top	Photoelectric Sensor + Ultrasound Scanner

Side	Laser Scanner Protection + Anti-Collision Bumper
Other	Emergency Stop Button + Acousto-Optic Alarm

\* Customizable fork length, fork outer width, and supporting legs outer width; Other available options: 5G communication, battery heating, safety anti-collision bumper, UWB safety system, barcode scanner, dash cam, RFID reader, etc.

Due to products upgrade, the specifications and parameters may be changed without notice. Please consult the sales for details.