

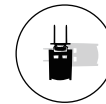

**6000kg**  
Rated Load Capacity



**1722mm**  
Min. Turning Radius



**3D SLAM**  
Positioning Method

# VNQ60(VL)-07 Autonomous Tow Tractor

Autonomous tractor is based on 3D SLAM navigation, It's maintenance is convenient. High parking Accuracy with high efficiency. 3D laser is capable of detecting high-level obstacles for safer transportation. IPX4 waterproof grade.



# VNQ60(VL)-07

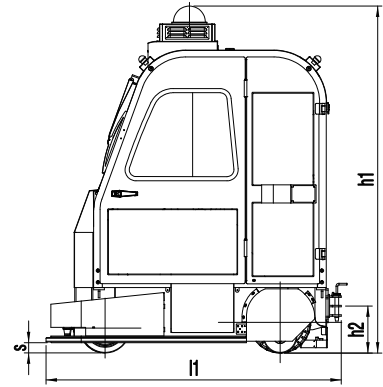
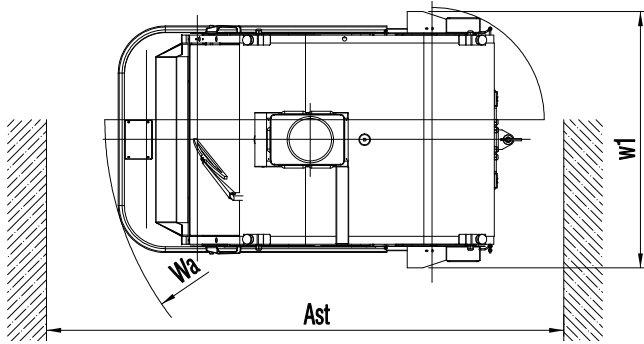

## TECHNICAL SPECIFICATIONS

Body Weight	1800kg (4078.55lb)
Rated Load Capacity	6000kg (13227.74lb)
Center Height of Traction Pin	210/275/340/405mm (8.27/10.83/13.39/15.94in)
Positioning Method	3D SLAM
Position Accuracy	$\pm 10\text{mm}/\pm 0.5^\circ$ ( $\pm 0.39\text{in}/\pm 0.5^\circ$ )
Min. Turning Radius	1722mm (67.80in)

Vehicle Dimensions (l1/b1/h1)	2001x1318x2390mm (78.78x51.89x94.09in)
Type of Operation	Automatic / Manual Seated
Battery Type	Lithium iron phosphate
Voltage/Battery Capacity	48V/300Ah
Charging Mode	Manual/ Automatic Charging

## MOTION PERFORMANCE

Max. Straight Forward Speed (Full-Load/Empty-Load)	2.0m/s, 2.0m/s (2.90mph, 2.90mph)
---	-----------------------------------

Max. Forward Turning Speed (Full-Load/Empty-Load)	0.3m/s, 0.6m/s (0.67mph, 1.34mph)
--	-----------------------------------

## ENVIRONMENTAL REQUIREMENT

Working Temperature	-5°C ~ 40°C
Working Humidity	20% ~ 95%
Ground Flatness	$\pm 5\text{mm}/\text{m}^2$ ( $\pm 0.20\text{in}/\text{m}^2$ )

Max. Climbing Capability (Full-Load/Empty-Load)	5%, 24% (2.8°, 13°)
Max. Groove Width	30mm (1.18in)
Max. Step Height	20mm (0.79in)

## SAFETY PROTECTION

Front	Laser Scanner Protection + Anti-Collision Bumper
Top	Ultrasound Scanner/Laser Scanner Protection

Side	Laser Scanner Protection+ Ultrasound Scanner+ Anti-Collision Bumper
Other	Emergency Stop Button + Acousto-Optic Alarm

\* Optional accessory: UWB ranging alarm system, magnetic markers guidance, hooking and unhooking module, battery heating package, RFID card reader, dashcam, etc.  
Due to improvements, the specifications and parameters may be changed without notice. Please consult the sales staff for details.