



**6613.87lb**

Rated Load Capacity



**3.36mph**

Max. Safety Driving Speed



**118.11in**

Fork Lifting Height



**151.57in**

Min. Stacking Aisle Width

# VNP30(VL)-07

## COUNTERBALANCE STACKER AGV

CE



**B56.5**

Taking advantages of 3D SLAM navigation and 3D laser perception module, the project implementation period is shortened and the AGV has high reliability; The AGV has 360-degree safety protection with customizable forks and other tools based on different scenarios, which provides high level safety, great flexibility, and strong adaptability.



# VNP30(VL)-07

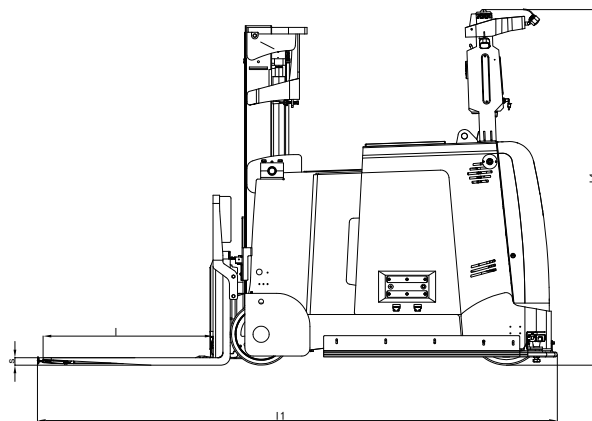
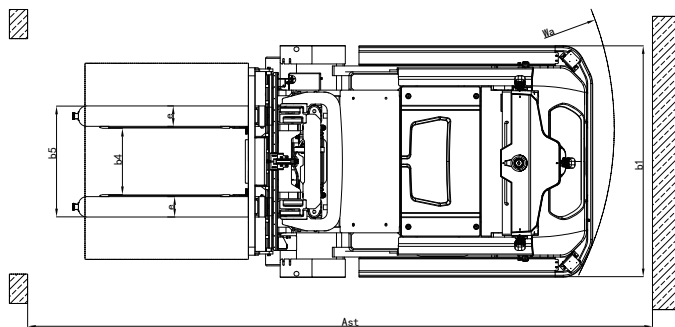

## TECHNICAL SPECIFICATIONS

Body Weight	10582.19lb (4800kg)
Vehicle Dimensions (l1/b1/h1)	127.95x55.91x85.43in (3250x1420x2170mm)
Fork Dimensions (l/e/s)	39.76x4.95x1.57in (1010x125x45mm)
Optional Fork Dimensions Series	33.86/45.70/51.57/57.48/63.39in (860/1160/1310/1460/1610mm)
Fork Outer Width	22.05/26.77in (560/680mm)
Fork Inner Width	11.30/15.98in (286/406mm)
Positioning Method	3D SLAM navigation
Perception Method	3D Laser scanner
Goods Pick-up Self-adaptability	±3.94in/±10° (±100mm/±10°)

Fork Lifting Height	118.11in (3000mm)
Rated Load Capacity	6613.87lb (3000kg)
Load Center Distance	19.69in (500mm)
Min. Turning Radius	79.53in (2020mm)
Locating Precision	±0.39in/±0.5° (±10mm/±0.5°)
Operation Mode	Automatic / Manual Handheld
Battery Type	Lithium iron phosphate
Voltage/Battery Capacity	48V/400Ah
Charging Mode	Manual/ Automatic Charging

## MOTION PERFORMANCE

Straight Forward Speed (Full-Load/Empty-Load)	2.91mph , 3.36mph (1.3m/s, 1.5m/s)
Straight Backward Speed (Full-Load/Empty-Load)	0.67mph , 0.67mph (0.3m/s, 0.3m/s)
Forward Turning Speed (Full-Load/Empty-Load)	0.67mph , 1.34mph (0.3m/s, 0.6m/s)

Backward Turning Speed (Full-Load/Empty-Load)	0.67mph , 0.67mph (0.3m/s, 0.3m/s)
Lifting Up Speed (Full-Load/Empty-Load)	0.48mph , 0.72mph (200mm/s, 320mm/s)
Lifting Down Speed (Full-Load/Empty-Load)	0.76mph , 0.65mph (340mm/s, 290mm/s)

## ENVIRONMENTAL REQUIREMENT

Min. Stacking Aisle Width (Pallet Size L*W:1219*1016mm, Across Forks On Length)	151.57in (3850mm)
Min. Turning Aisle Width (Pallet Size L*W:1219*1016mm, Across Forks On Length)	101.77in (2585mm)
Working Temperature	-5°C~40°C
Working Humidity	20%~95%

Ground Flatness	±0.20in/m <sup>2</sup> (±5mm/m <sup>2</sup> )
Max. Climbing Capability (Full-Load/Empty-Load)	5%, 5% (3°, 3°)
Max. Groove Width	1.18in (30mm)
Max. Step Height	0.39in (10mm)

## SAFETY PROTECTION

Front	Laser Scanner Protection + Anti-Collision Bumper
Rear	Laser Scanner Protection + Contact Sensor
Top	Photoelectric Sensor + Ultrasound Scanner

Side	Laser Scanner Protection + Anti-Collision Bumper
Other	Emergency Stop Button + Acousto-Optic Alarm

\* Customizable fork length, fork outer width, and supporting legs outer width; With duplex mast option, the lifting height can reach 118.11in, 137.80in, 157.48in, and 177.17in. With triplex mast option, the lifting height can reach 177.17in (body weight varies slightly with different mast selections); Available fork type options: Side shifter and adjustable forks; Other available options: 5G communication, battery heating, battery trolley for battery swap, loads over height detection, UWB safety system, barcode scanner, dash camera, RFID reader, etc.  
Maximum load capacity varies with lifting height, please refer to load capacity curve.

All the above parameters are obtained from the factory testing environment of standard products, and the vehicle parameters and performance of the project may vary according to actual conditions. Due to iterative upgrades on products, some of the specifications being listed above and the appearance of the products may not be able to change in time. For details, please contact our salespersons.