



4409.25lb

Rated Load Capacity



6.04mph

Max. Safety Driving Speed



118.11in

Fork Lifting Height



140.16in

Min. Stacking Aisle Width

VNE20(VL)-07

COUNTERBALANCE STACKER AGV



B56.5

Counterbalanced forklift AGV is based on 3D SLAM navigation+3D laser adaptive sensing, which can make the project import fast and the forking repeatability high;The vehicle is capable to drive faster and overcome steeper routes. Narrow body design, supporting fork length, outer width and outrigger customization according to the scene, with great flexibility and stronger adaptability.



VNE20(VL)-07

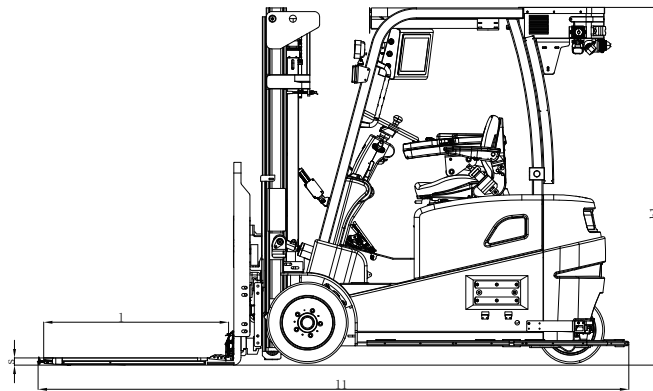
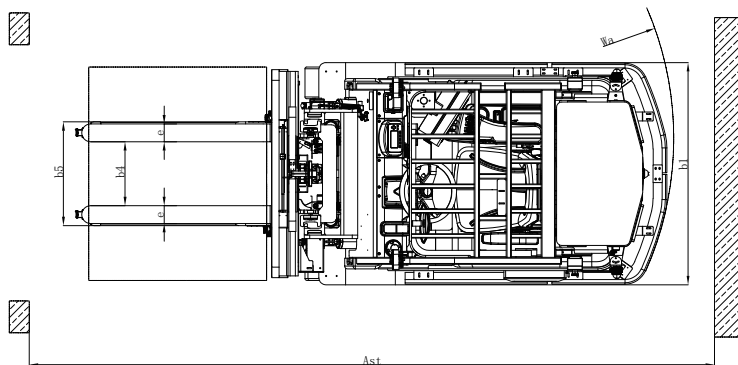

TECHNICAL SPECIFICATIONS

Body Weight	7385.49lb (3350kg)
Vehicle Dimensions (l1/b1/h1)	126.85x49.21x80.12in (3222x1250x2035mm)
Fork Dimensions (l/e/s)	40.94x3.94x1.57in (1040x100x40mm)
Optional Fork Dimensions Series	35.04/46.85/52.76/58.66/64.57/70.47in (890/1190/1340/1490/1640/1790mm)
Fork Outer Width	17.72/39.37in (450/1000mm)
Fork Inner Width	8.86/30.51in (225/775mm)
Positioning Method	3D SLAM navigation
Perception Method	3D Laser scanner
Goods Pick-up Self-adaptability	±3.94in/±10° (±100mm/±10°)

Fork Lifting Height	118.11in (3000mm)
Rated Load Capacity	4409.25lb (2000kg)
Load Center Distance	19.69in (500mm)
Min. Turning Radius	72.24in (1835mm)
Stacking Accuracy	±0.39in/±0.5° (±10mm/±0.5°)
Operation Mode	Automatic / Manual Seated
Battery Type	Lithium iron phosphate
Voltage/Battery Capacity	48V/400Ah
Charging Mode	Manual/ Automatic Charging

MOTION PERFORMANCE

Straight Forward Speed (Full-Load/Empty-Load)	6.04mph , 6.04mph (2.7m/s, 2.7m/s)
Straight Backward Speed (Full-Load/Empty-Load)	0.67mph , 0.67mph (0.3m/s, 0.3m/s)
Forward Turning Speed (Full-Load/Empty-Load)	2.24mph , 2.24mph (1.0m/s, 1.0m/s)

Backward Turning Speed (Full-Load/Empty-Load)	0.67mph , 0.67mph (0.3m/s, 0.3m/s)
Lifting Up Speed (Full-Load/Empty-Load)	0.58mph , 0.76mph (260mm/s, 340mm/s)
Lifting Down Speed (Full-Load/Empty-Load)	0.67mph , 0.67mph (300mm/s, 300mm/s)

ENVIRONMENTAL REQUIREMENT

Min. Stacking Aisle Width (Pallet Size L*W:1219*1016mm, Across Forks On Length)	140.16in (3560mm)
Min. Turning Aisle Width (Pallet Size L*W:1219*1016mm, Across Forks On Length)	95.86in (2435mm)
Working Temperature	-5°C ~ 40°C
Working Humidity	20% ~ 95%

Ground Flatness	±0.39in/m ² (±10mm/m ²)
Max. Climbing Capability (Full-Load/Empty-Load)	13%, 15% (7°, 8.5°)
Max. Groove Width	1.97in (50mm)
Max. Step Height	1.18in (30mm)

SAFETY PROTECTION

Front	Laser Scanner Protection + Anti-Collision Bumper
Rear	Laser Scanner Protection + Contact Sensor
Top	3D Laser Scanner Protection

Side	Laser Scanner Protection + Anti-Collision Bumper
Other	Emergency Stop Button + Acousto-Optic Alarm

* Side shifter is standard configuration; Optional fork length, fork outside width; Optional duplex mast lifting height 3000mm, 3500mm, 4000mm, 4500mm, triplex mast lifting height 4500mm (body weight with the height of the door slightly different); Optional, pitch fork, 5G communication, battery heating, battery trolley, cargo ultra high detection, UWB warning system, scan gun, traffic recorder, RFID card reader, etc.

Maximum load capacity varies with lifting height, please refer to load capacity curve.

All the above parameters are obtained from the factory testing environment of standard products, and the vehicle parameters and performance of the project may vary according to actual conditions.

Due to iterative upgrades on products, some of the specifications being listed above and the appearance of the products may not be able to change in time. For details, please contact our salespersons.